

Bär Marinelift Standard



System information

For small and midium size yachts with a huge deck surface overhang behind the stern.

Predestined for double Z-drive. This Marinelift system in combination with the Marinelift model BM 3-400S and BM 4-600S (mono-arm) is used favorably for yachts with double Z-drive.

The use of the bigger Marinelift types is possible, but depends on the design of the hull.

Advantages of the Bär Marinelift Standard:

- The Marinelift Standard has a simple construction consisting out of a few but very robust components.
- The electric control is operated by relays. Therefore easy to handle without any special knowledge.
- Well-priced Marinelift system.
- Control functions: Lifting and tilting.

For the retrofitting on conventional yacht types we provide complete kits with GRP platforms.

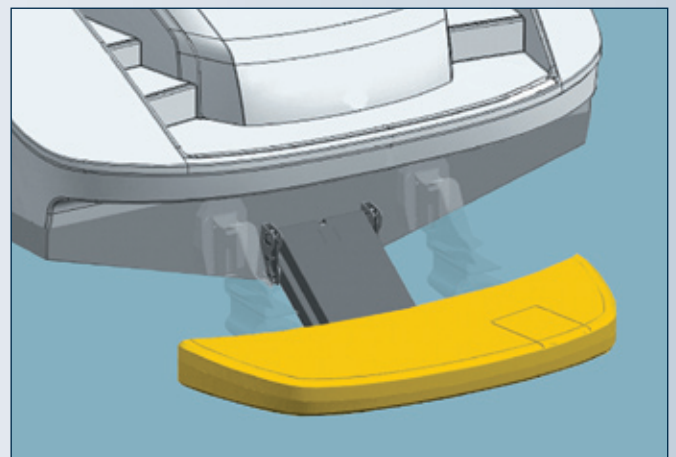
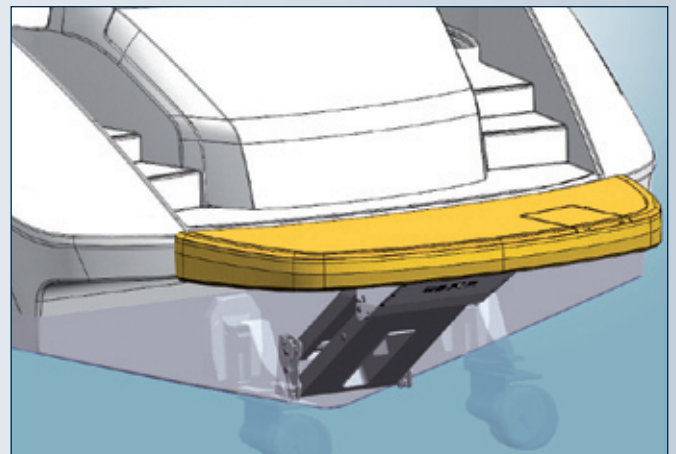
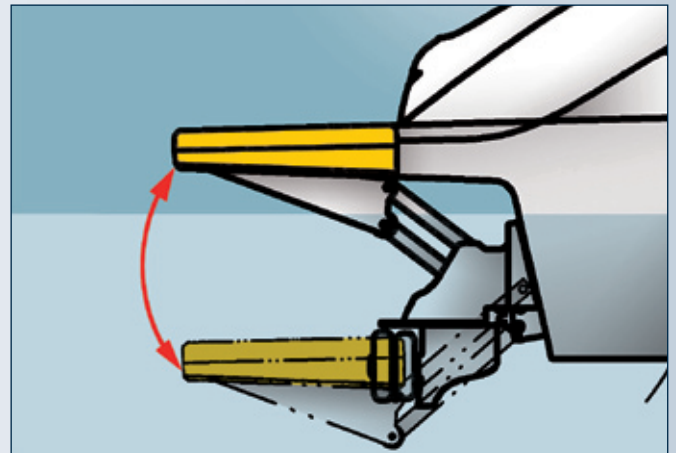

Bär Marinelift Standard BM 3 – 411S

Retrofit kit for Bavaria 33 / 37 / 38



www.baer-nauticboarding.com

Bavaria	33	37/38
Load moment	3 kNm	3 kNm
Capacity	400/500 kg	400/500 kg
Load distance	750 mm	750 mm
Platform width	3000 mm	3230/3500 mm*
Platform depth	800 mm	800/1200 mm*
Diving depth	465 mm	545 mm
Weight (without Teak)	135 kg	140/165 kg*

For other yachts on request.

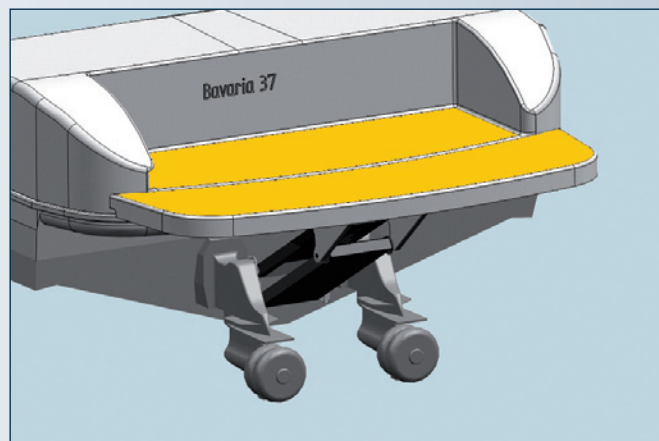
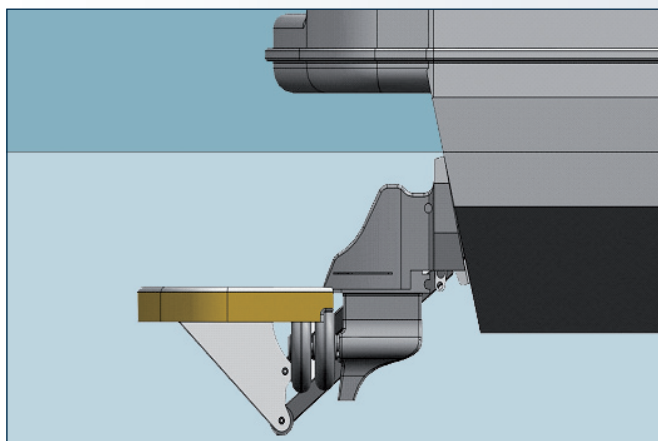
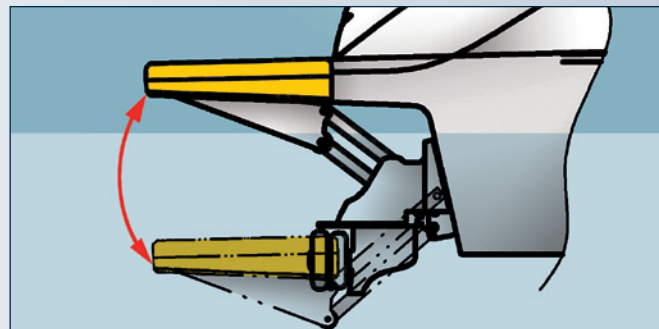

Scope of delivery Bär Marinelift Standard BM 3 - 411S:

- lifting mechanism out of aluminium, surface coating, prepared for Triflux Antifouling, set sacrificial anode
- GFK platform fitting for Bavaria 33 / 37 / 38
- power pack 12V with double relais and mini-SPS control, as well as hydraulic valves
- emergency control for lifting
- connection plug and play
- fitting material, cables to battery and cockpit, oil filled
- 4-channel radio remote control with two manual transmitters

* Larger platform necessary for jetski / tender boat.
Supports available.

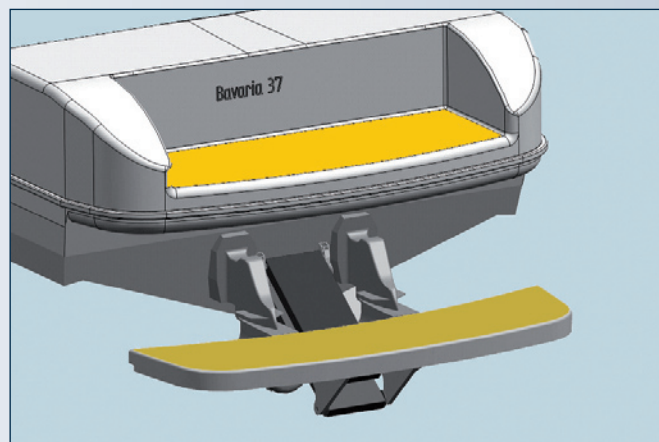

Version: 07.09.09