

Bär Marinelift StandardPlus



System information

For yachts of all sizes that have no or a small deck surface behind the stern.

The Marinelift with the largest diving depth by horizontal operation of the platform.

In comparison to the Marinelift Standard, the StandardPlus platform is not firmly attached to the lifting mechanism, but it is relocatable. The displacement is done mechanically by the lifting and lowering movement (displacement mechanics).

In contrast to the Marinelift systems SliderParty and Slider-Boat there is no additional drive available.

- Control functions: Lifting and tilting.

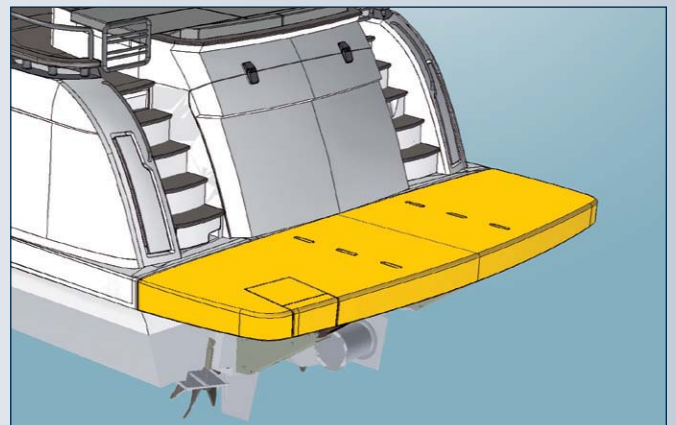
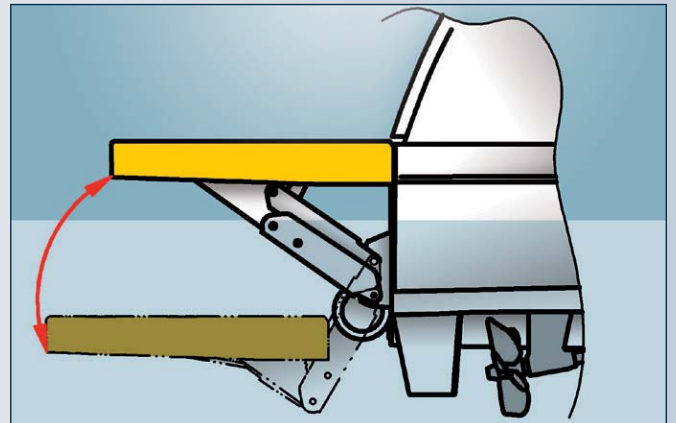

In the lowered position, the platform is fully extended. This results in more room for the lifting arms and thus a greater diving depth. Additionally there is more space for the aileron, balance assy, etc.

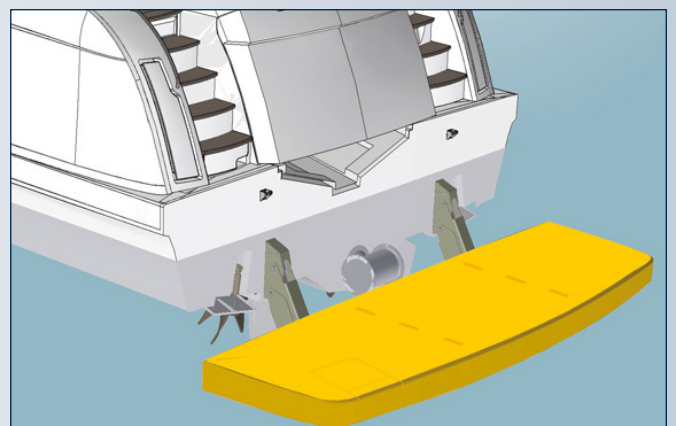

Bär Marinelift StandardPlus

Fitment example BM 6- 722SP/1209



Trawler fitment without deck surface



Displacement mechanics lifted position
Platform lifted and retracted to the transom



Cruising position



Displacement mechanics lowered position
Platform fully extended at the bottom



Diving position



Stable and low weight aluminium profiles form the basis for:

- platform cover out of GRP
- safety interlock
- rail gates